



COMPANY **PROFILE**



Welcome
to **amtec**[®]

INTRODUCTION

Being established in 2007, until now, AMTEC is one of the top brands in the IT and telecommunications equipment industry.

We are currently manufacturing the items for Network Cabinet, Equipment Rack systems, Enclosures, Cable Ladder, Cable Trays, PDU, and other accessories.

AMTEC's products are suitable for all projects, from Big scale's Datacenter, Complex systems, to small and medium size networks.

AMTEC's products are present and easily found in Vietnam and over nine countries in Southeast Asia.

TABLE OF CONTENTS

Introduction - Table of Contents	2
Company Information	3
History - Achievements	4
AMTEC System	6
Vision and mission - Motto	8
Capacity in machinery and technology	10
AMTEC's products	14
Porrtfolio	22

COMPANY INFORMATION

AMTEC Co., Ltd.

Factory:

17/3 Binh Quoi A, Binh Chuan, Thuan An, Binh Duong, VIETNAM.

Tel: (84-274) 3612 177 **Fax:** (84-274) 3612 178

Sale Office:

C5-29 Charmington La Pointe, 181 Cao Thang st. Dist 10. HCMC. VIETNAM

Tel: (84) 0908019061; (84) 0902400664

http://www.amtec.com.vn

Email: sale@amtec.com.vn



HISTORY AND ACHIEVEMENTS

The group of shareholders established NSP in 1999 and the AMTEC factory in 2006. They jointly owned the Vietrack brands distributed domestically, the AMTEC brand exported to 9 ASIAN countries and projects in the US, France, Australia ...

In 2015, NSP split from AMTEC. Then, AMTEC distributed its products to the domestic market and terminated the production of the Vietrack brand in 2017.

At this time, AMTEC expanded its factory area 3 times and increased the capital to 200% for investing in technology and new generation production lines.

The factory is most modern with the complete infrastructure and applies Kaizen and 5S in production management.

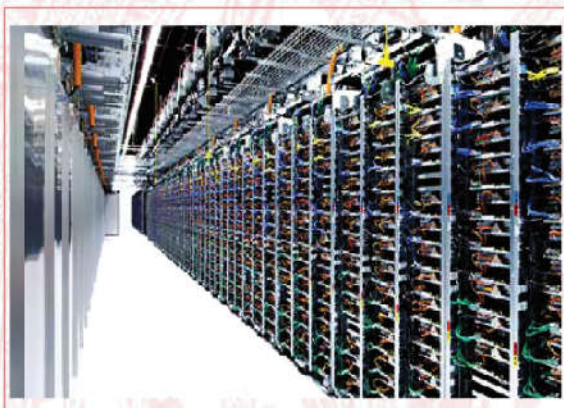
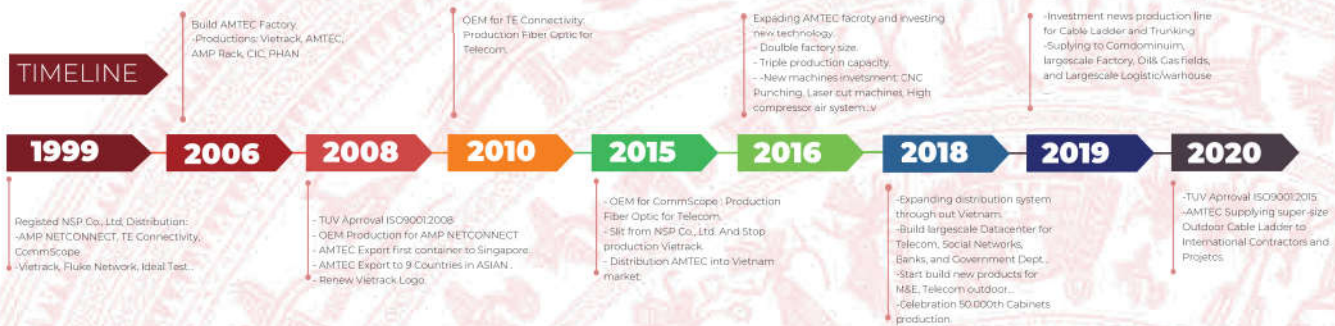

At this time, AMTEC has gained many achievements:

- International quality management system ISO 9001: 2008 was appraised and certified by TUV Findland. Strict management from raw materials, production to finished packaging and delivery.
- Quality management system is comprehensive and qualified, specializing in providing for AMP, TE Electronics, Commscope.

- An OEM manufacturing partner with more than 10 brands, supplying Cabinet and accessories for almost 100 big Datacenter at home and abroad.

- The variety of products from Datacenter, Server, Network, Open rack, PDU, cable ladder, to Telecom, Shelter, BTS, and power stations!

- More than 30,000 Cabinet and all kinds of accessories have been manufactured and distributed widely in Vietnam and ASIAN countries, affirming a reliable value and quality.



- Optimal sales service, direct delivery from factory to works if required, maximizing profit for partners.
- Professional warehouse system and Logistics services.
- Launching service to support installation in large projects if required.
- Developing warranty services and solving problems at projects if required.

MANAGEMENT SYSTEM

The factory with modern facilities is arranged to produce according to:

1. ISO 9001: 2015 STANDARD
2. PRODUCTION STANDARDS BY 5S,
3. STRONG INVESTMENT IN SPECIALIZED IN PRODUCTION CONTROL PROCESS - TQM,
4. TECHNOLOGY INNOVATION - KAIZEN,
5. SAVING AND COMPACT PRODUCTION - LEAN MANUFACTORY,
6. DIRECTIONS TO MODERN PRODUCTION TECHNOLOGY 4.0 INDUSTRIES

These are the most important criteria in organizing the production standards



ISO 9001:2015



INTERNATIONAL QUALITY MANAGEMENT SYSTEM

With the determination to build a technical team, invest in a modern production line, AMTEC has met strict international standards such as:

- Achieved ISO 9001 certification by TUV organization.
- Certified as an OEM supplier of:





DISTRIBUTION SYSTEM

AMTEC has achieved achievements:

Producing more than 50,000 equipments to serve domestic demand.

Agent system spread across provinces and cities in the country

Build on 10 STRATEGIC PARTNERS.

Connect with over 50 GOLDEN AND SILVER PARTNERS.



EXPORTING DISTRIBUTION SYSTEM

Successfully built up the export distribution system to countries in the ASIAN region, including:

SINGAPORE, THAILAND, CAMBODIA, MYAMAR, PHILIPINE, INDONESIA, MALAYSIA

And some projects at:

USA, FRANCE, AUSTRALIA, HONGKONG

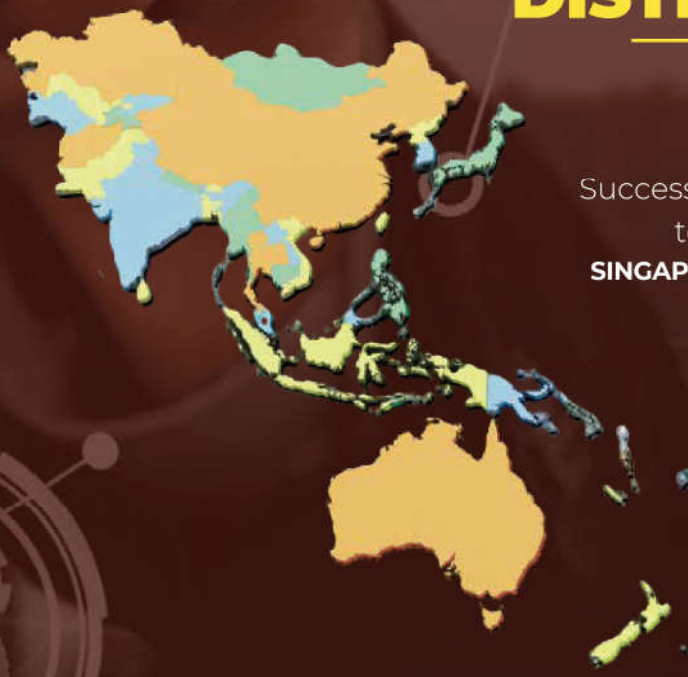

VISION & MISSION



Satisfying all customers' needs and expectations with modern technology, professionalism, and dedication.



Aiming for the perfection and professionalism of the company's product lines. Approaching advanced standards, modern and new technology in the world.



Strictly implementing the regimes and policies of the state, joining hands in building a better society.



Searching, creating, and improving solutions and technologies to enhance the quality and reduce the price of products, providing customers with increased value.



Committed to develop, implement, maintain, and improve the effectiveness of the quality management system under ISO 9001: 2008.



Respecting human resources and committing to creating the best conditions at work and taking care of all employees' life.

The AMTEC's motto is:

“CLOSE - CREATIVE - PROFESSIONAL”

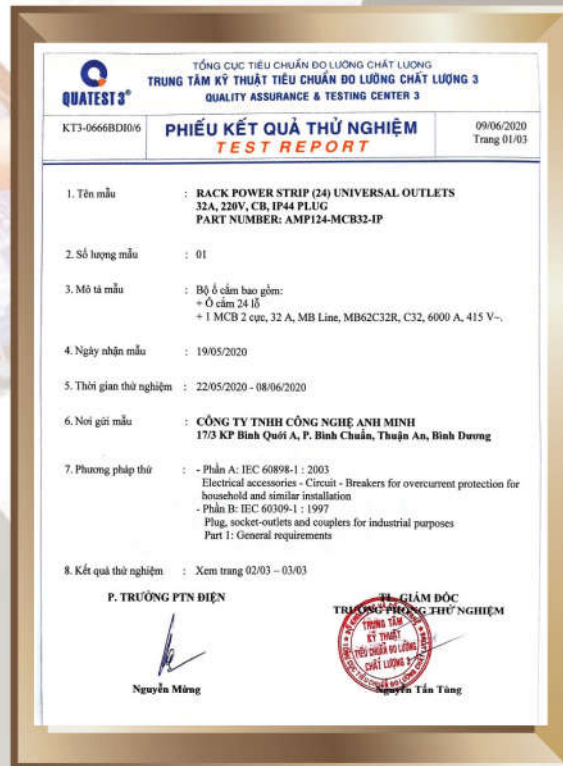
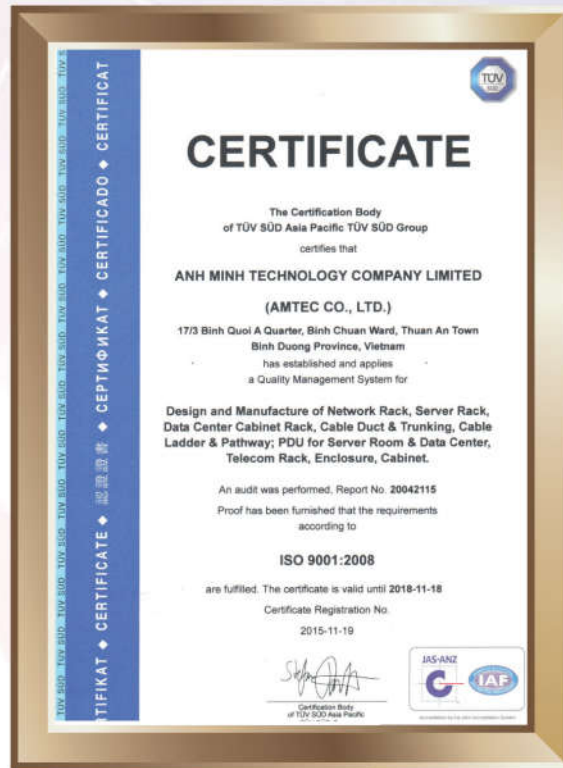

CERTIFICATIONS

CAPACITY IN MACHINERY EQUIPMENT AND TECHNOLOGY

Factory:

- The factory is situated on a private campus, including the tall and spacious plants built in a modern and solid steel construction.
- Large and modern office with a showroom displaying the factory's product lines and providing solutions to customers.

List of machinery and equipment:



- 560KVA 3-phase power supply system: Separate power supply system, ensuring a constant and stable power source for high-tech machines in the production line.



- Main dynamic power distribution system with professionally decentralized power cabinets, supplying power to each work station with multiple levels of safe and stable protection. Explosion-proof and lightning-proof ensure safety for people and sensitive and high-tech CNC machines.



- Rotary screw compressor, water separator, and compressed air dryer system supply dry and clean compressed air to each working station.



- The AMADA and KRRAS cutting machine is capable of cutting all kinds of plate steel, stainless steel, aluminum, copper ... with a thickness of from 0.5 to 6mm and a length of up to 4 meters.



- AMADA and EUROMAC punching machine: is the central machine system in CNC technology for plate steel processing, with outstanding technology of AMADA - Japan and EUROMAC – Italy, leading the world in speed and accuracy up to ~ 0.1mm. It is a world-leading technology making precision plate steel products at the moment.



- CNC Fiber Laser Cutting Machine: CNC Fiber Laser cutting machine is the latest technology in plate steel processing. It can cut accurately at fast speeds, machining all cutting lines according to the CNC drawing board for almost unlimited processing of plate steel products.
- Unlimited machinability with all dash lines up to 20mm in thickness.



- Bending machine system - Bending

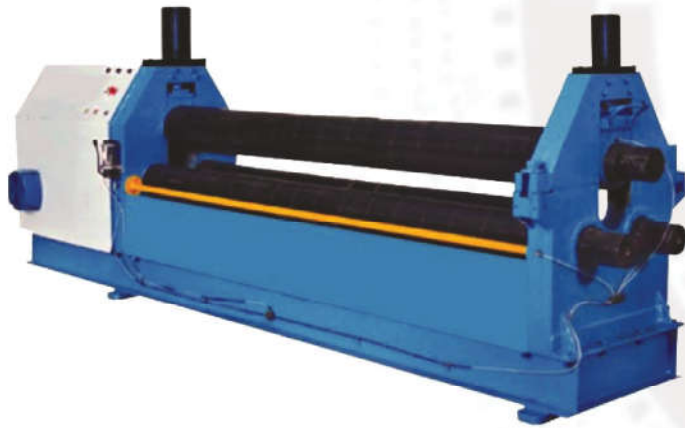

- System of bending machines up to 3 meters long: Formats, creates hardness and shape of products.

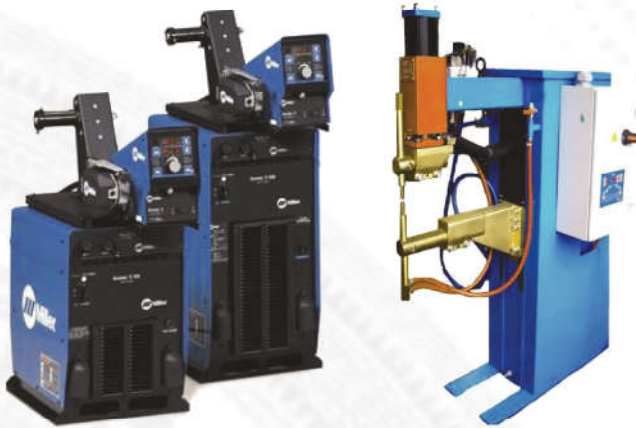

- Electrostatic painting system: The paint system is complete, coated with zinc NANO, increasing coverage, and friendly with the environment.



- The complete paint room and oven system controls the quality of the products consistently when painting the finished products.

PRODUCT LINE

AMTEC

- ★ ROYAL DATACENTER™
- ★ SERVER CABINET™
- ★ AMRACK™
- ★ PDU
- ★ TRUNKING
- ★ CABLE LADDER
- ★ ASSESSORIES



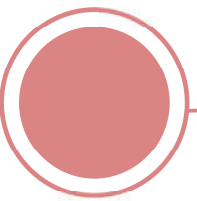
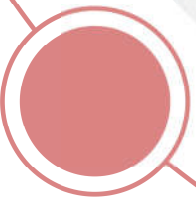
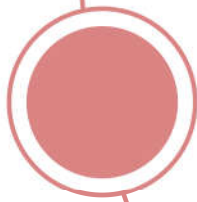

ROYAL DATACENTER™



4 side doors with light weight

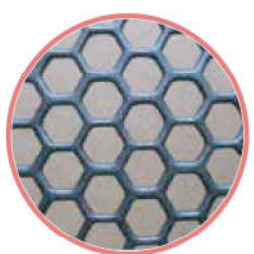

Hexagonal door front and back perforated for 80% ventilation



The mounting profile; Clear ID and U-high number



X'truk™ 9 edges frame, Loading upto 1500 KGS



iFlex-Frame™ Multi-point connection, easy to adjust



4 Heavy duty feet, Loading upto 1500 KGS

SERVER CABINET



4 side doors with light weight



Hexagonal door front and back perforated for 80% ventilation



The mounting profile: Clear ID and U-high number



X'truk™ 9 edges frame, Loading upto 1250 KGS



iFlex-Frame™ Multi-point connection, easy to adjust



4 Heavy duty feet, Loading upto 1250 KGS



AMRACK™

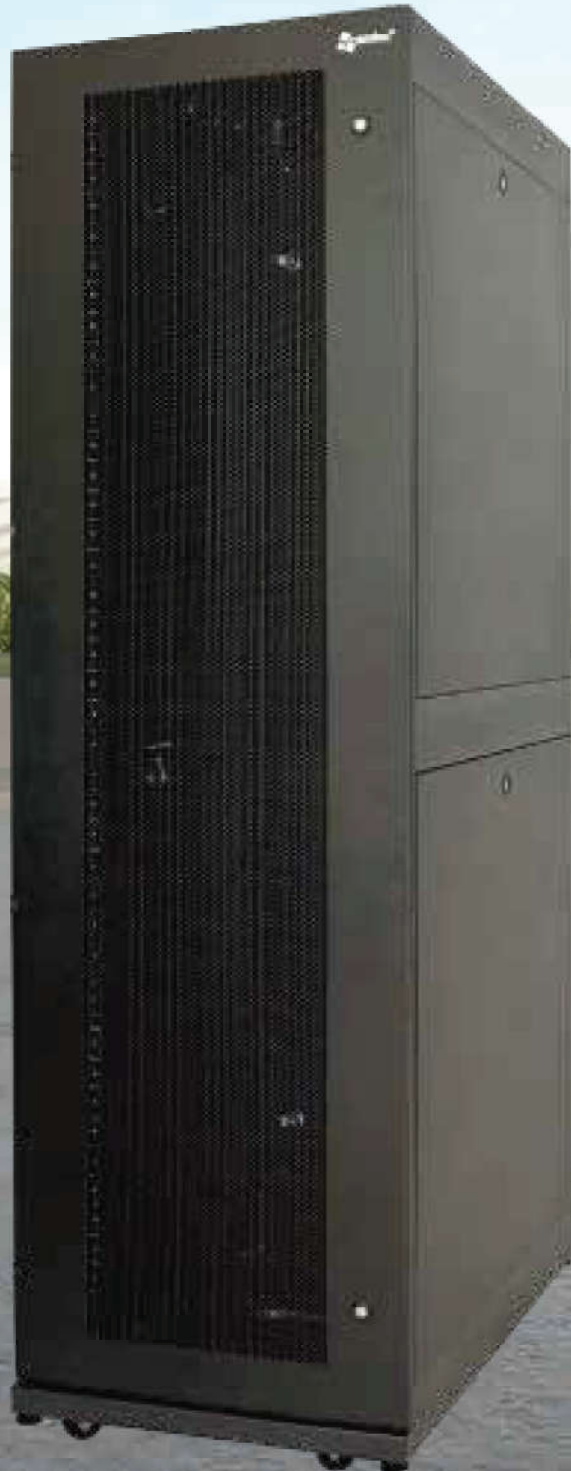

4 side doors with light weight



Hexagonal door front and back perforated for 65% ventilation



The mounting profile: Clear ID and U-high number



X'truk™ C frame, Loading upto 650 KGS



iFlex-Frame™ Multi-point connection, easy to adjust



4 Leveling feet, Loading upto 650 KGS



**INTERNATIONAL STANDARD
CABINET / RACK SYSTEM FOR DC**



**AIR SYSTEM
HOT AND COLD**



**HORIZONTAL & VERTICAL
CABLE MANAGEMENT SYSTEM**

AMTEC PDU



Industrial Plug:
15A, 32A, 64A.



Universal, USA, Australia,
UK, French...



C13, C14, C19,
C20 Outlet



MCB: 15A, 32A,
64A...





LADDER SYSTEM



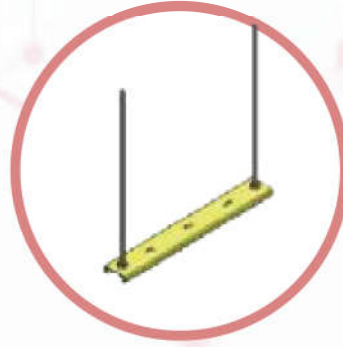
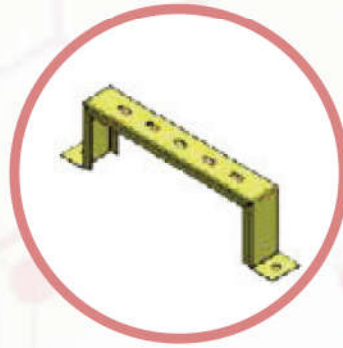
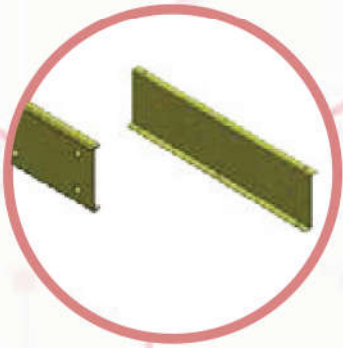

LADDER

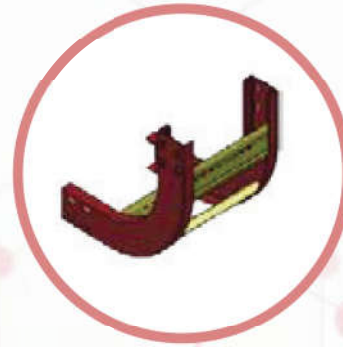

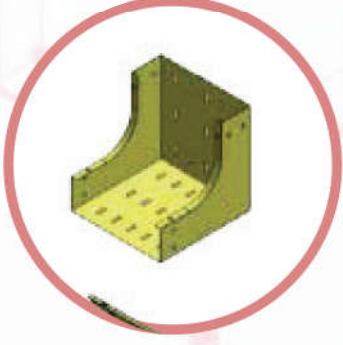
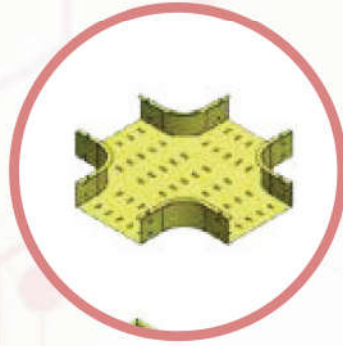
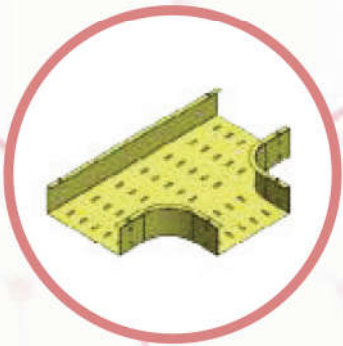

TRUNKING

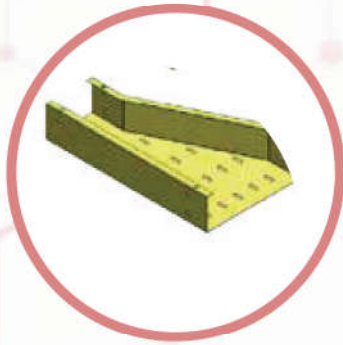
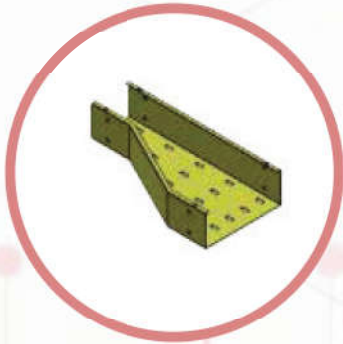
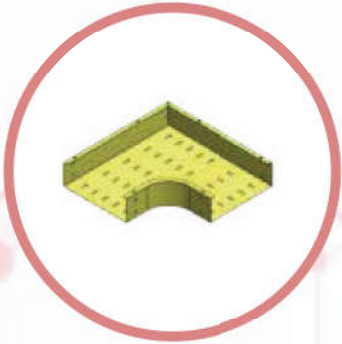

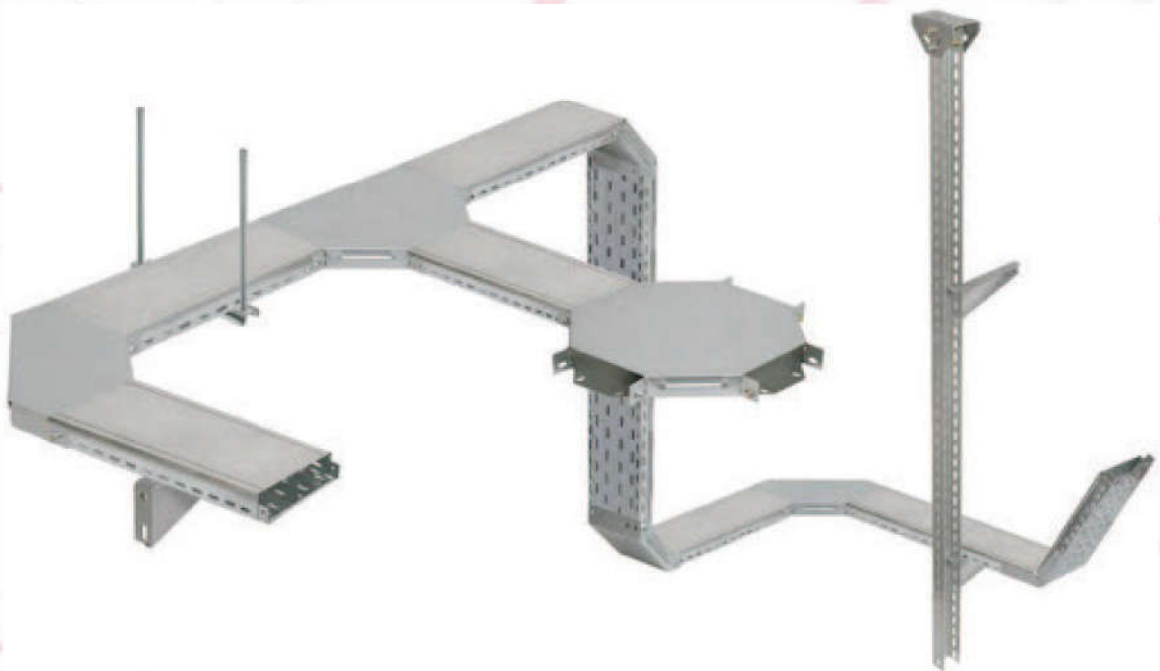

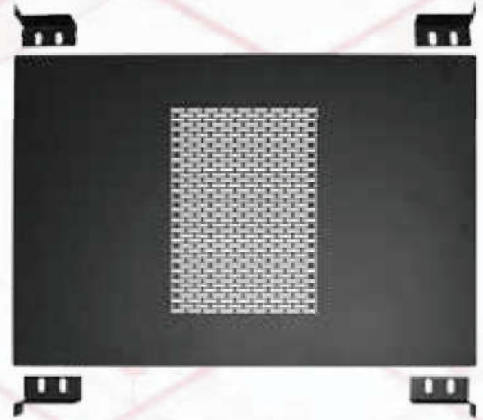
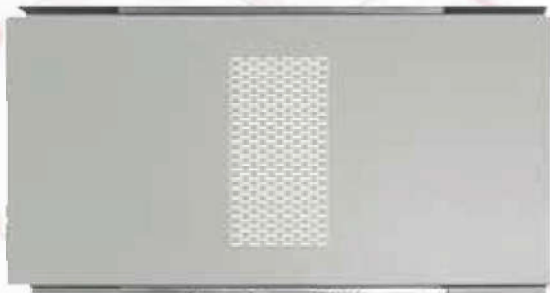

ACCESSORIES

PARTNERS





Datacenter/ Distribution Partners



KEY PROJECTS

1. Government Projects:



Parliament building



Binh Duong Administrative center



National convention center



Ministry of Public Security



Ministry of Finance



Long An Administrative center



Government office



People's Committee of Ho Chi Minh City



Da Nang Administrative center

2. Bank



Vietcombank



Sacombank



OUB Bank



HSBC Bank

KEY PROJECTS

3. Office Building:



Sun Wall



Metropolitan



Bitexco Final



Saigon Tower



Lim Tower

4. Hotel/Condominium:



New World Hotel



Rex Hotel



Sofitel



Caravelle



Sheraton

5. Factory, Oil & Gas...



NAT&L Factory



Rubber tire KUMHO Factory



Chip Intel Factory



Heineken Factory



Hyosung Factory



AEON Mall



Nguyen Kim Mall

PORTFOLIO







Ann



ANH MINH TECHNOLOGIES CO., LTD

FACTORY: 17/3 BINH QUOI A, BINH CHUAN, THUAN AN, BINH DUONG, VIETNAM

PHONE: (84-0274) 3612 177 - **WEBSITE:** WWW.AMTEC.COM.VN